

COATS®

4050A

Tire Changer

For servicing single piece automotive and most light truck tire/wheel assemblies

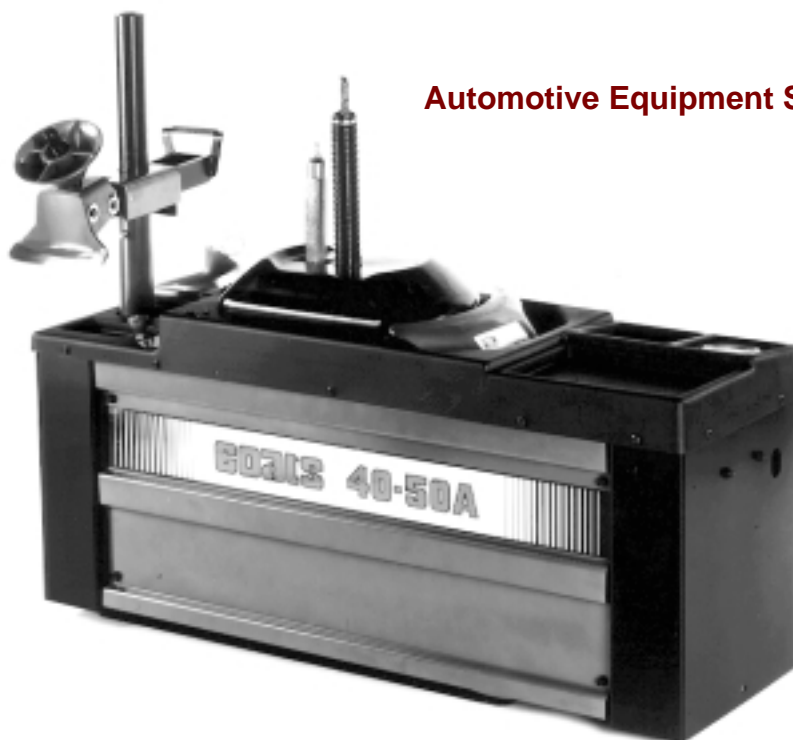

Order Parts From:
Automotive Equipment Sales and Services
1.800.749.5990
www.autoess.com

Parts Identification

READ these instructions before placing unit in service KEEP these and other materials delivered with the unit in a binder near the machine for ease of reference by supervisors and operators.

HENNESSY INDUSTRIES, INC.

HENNESSY INDUSTRIES INC. Manufacturer of AMMCO®, COATS® and BADA® Automotive Service Equipment and Tools.

Manual Part No.: 8183744 01
Revision: 07/97

Parts Identification

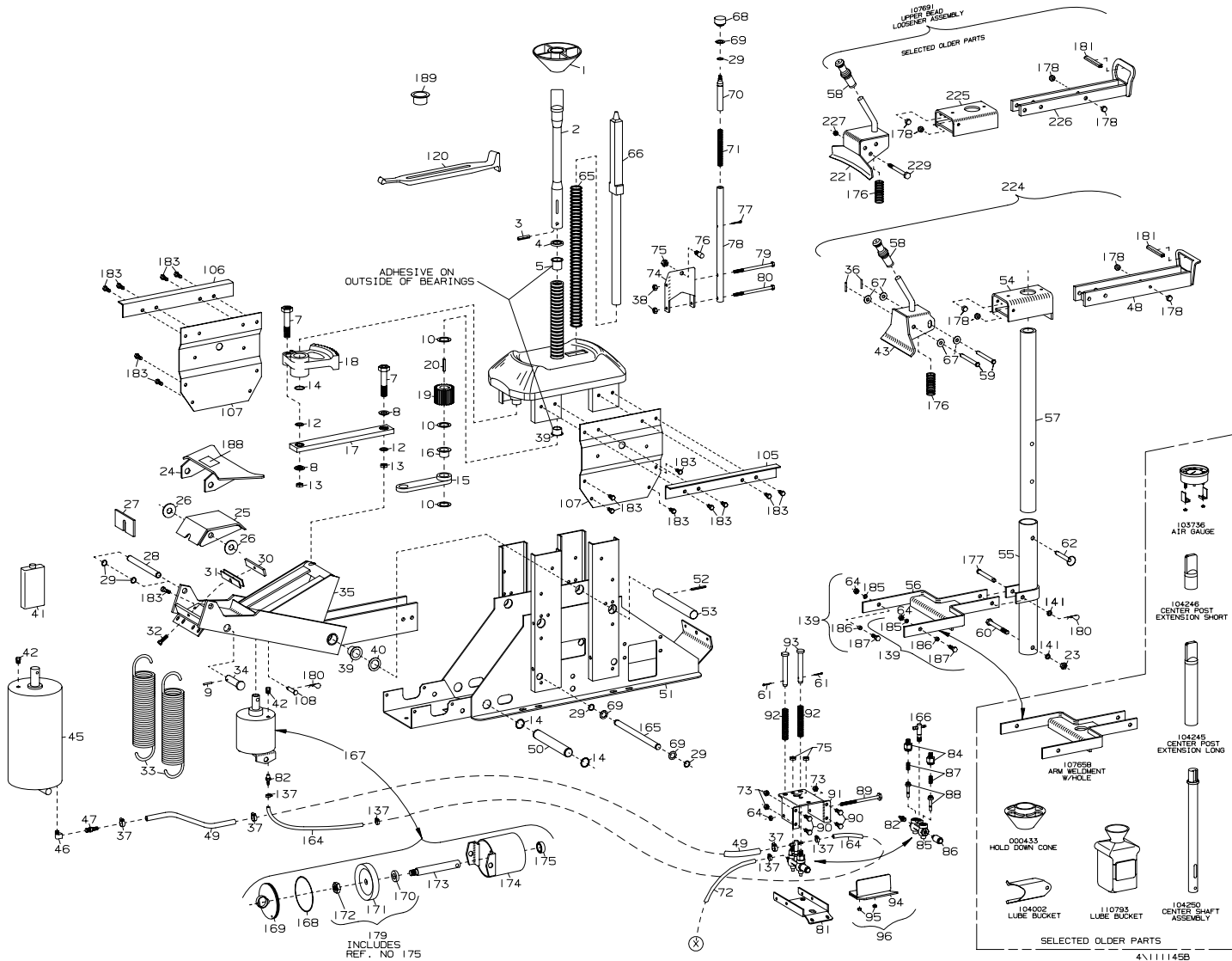

Parts Identification

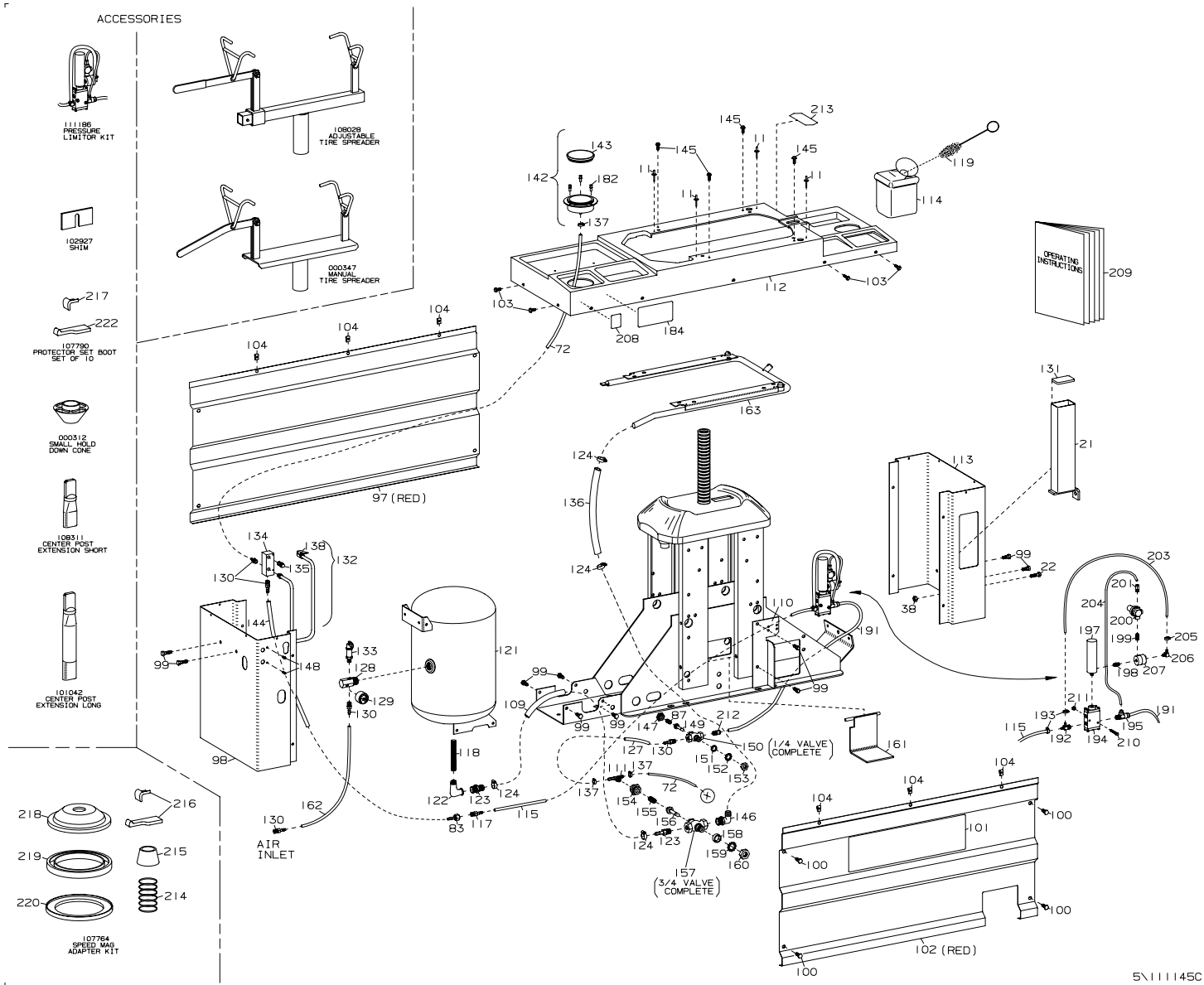

Parts Identification

Ref	Part No.	Description	Ref	Part No.	Description
1	8108276	Centering Cone	60	8107663	HHCS 1/2" x 4-3/4", Gr.5
2	8108289	Center Shaft	61	8102278	1/8" x 1 Cotter Pin (Ea.)
3	8000304	3/8" x 1-3/4" Roll Pin	62	8107665	Clevis Pin Detent
4	8108290	Center Post Washer	64	8000516	3/8" Lock Nut, Gr.5
5	8000510	1-1.4" x 1-1/4" Nylon Bearing	65	8108292	Positioning Pin Spring
7	8101296	3/4" Drive Gear Bolt, Gr.5	66	8108291	Positioning Pin
8	8100958	Self-Aligning Washer	67	8108265	1/2" Machine Bushing
9	8100602	3/16" x 1-1/4" Roll Pin	68	8104155	Knob
10	8101651	1-1/4" Machine Bushing (Ea.)	69	8103264	3/4"x1-1/4" Machine Bushing
11	8108593	3/16" Dia. Rivet (Ea.)	70	8104262	Push Handle
12	8108280	3/4" Machine Bushing	71	8104284	Detent Spring
13	8100957	3/4" Lock Nut N.C. (Ea.)	72	8106288	1/4" Hose 16-1/4"
14	8100964	1-1/4" Snap Ring (Ea.)	73	8106303	3/8" Whiz Lock Nut, Gr.5
15	8101298	Gear Tie Bar	74	8104120	Support Bracket
16	8101352	Tie Bar Nylon Bearing	75	8103260	1/2" Lock Nut N.F., Gr.5
17	8101089	Drive Gear Bar Assembly	76	8104354	Stud Kit
18	8104247	Drive Gear Complete	77	8103006	5/32" x 1-1/4" Cotter Pin
19	8100951	Pinion	78	8106230	Arm Detent
20	8101091	Shaft Key	79	8110653	3/8" x 6" Cap Screw, Gr.5
21	8107770	Combo Tool Holder	80	8110653	3/8" x 6" Cap Screw, Gr.5
22	8107715	HHCS 3/8 - 16 x 1-1/4" GR.5	81	8104108	Foot Valve Plate
23	8101039	1/2" Lock Nut N.C., Gr.5	82	8000378	1/4" Straight Fitting
24	8101042	Large Lower Shoe	83	8108605	Female Coupler Assembly
25	8108951	Small Lower Shoe	84	8104355	Valve Cap (Ea.)
26	8100994	Shoe Spacer	85	8104266	Valve Complete
27	8102927	1/4" Shim	86	8104209	Muffler
28	8101003	Lower Shoe Shaft	87	8102468	Poppet String (Ea.)
29	8101001	3/4" Snap Ring (Ea.)	88	8102469	Poppet (Ea.)
30	8105133	1/4" Shoe Adjusting Bar	89	8110653	3/8" x 6" Cap Screw, Gr.5
31	8101506	Shoe Adjusting Shim Kit	90	8107413	Bolt S.W.H. 3/8" x 1", Gr.5
32	8105131	3/8" x 1-1/4" Self Tapping Bolt, Gr.5	91	8104110	Valve Bracket
33	8104012	Return Spring (Ea.)	92	8104149	Valve Spring
34	8101002	Upper Cylinder Clevis Pin	93	8104154	5/8" x 4-1/2" Clevis Pin (Ea.)
35	8107195	Power Arm	94	8106035	Foot Pedal
36	8108602	3/16" x 1-1/4" Roll Pin	95	8000525	5/16" Lock Nut N.C. (Ea.)
37	8101427	Hose Clamp	96	8106190	Foot Pedal Kit
38	8000516	3/8" Lock Nut, Gr.5	97	8111147	Side Panel Rear Complete
39	8101351	Nylon Bearing (Ea.) w/Flange	98	8106247	End Panel Left
40	8101651	Machine Busing (Ea.)	99	8102459	3/8" Self-Tapping Screw, Gr.5
41	8101411	1 Qt. Special Hyd. Oil (Ea.)	100	8102459	3/8" Self-Tapping Screw, Gr.5
42	8105678	Plastic Breather Plug	101	8110824	Warning Decal
43	8108131	Shoe W/C	102	8108298	Side Panel Front Complete
44			103	8106301	1/4" Hex Whiz Lock Self-Tapping Screw, Gr.5
45	8107242	7" Cylinder	104	8106304	Skin Fastener Tinnerman
46	8000372	1/4" x 90° Street Elbow	105	8108584	Angle Top Support
47	8101898	3/8" Hose Fitting	106	8108584	Angle Top Support
48	8108134	Bar Weldment	107	8108130	Plate Chassis Stiffener
49	8107240	3/8" Hose 23-1/2"	108	8107238	7/16" x 2" Clevis Pin
50	8101000	Lower Cylinder Shaft	109	8108319	3/4" Hose 27-1/2"
51	8108331	Chassis Weld Assembly	110	8110533	Inflation Limiter Bracket
52	8101371	1/4" x 2-1/4" Roll Pin	111	8106278	Male Branch Tee
53	8100970	Power Arm Axle	112	8107922	Plastic Top Cover
54	8108135	Channel W/C	113	8106248	End Panel Right
55	8107655	Large Tube W/C	114	8106572	Bottle - Lube
56	8111025	Arm Weldment	115	8106289	1/4" Hose 22"
57	8100979	Tube Small	117	8102390	1/4" Push On Fitting
58	8100979	Top Bead Loosener Handle Grip	118	8106188	Strainer Screen
59	8111148	Clevis Pin			

Parts Identification

Ref	Part No.	Description	Ref	Part No.	Description
119	8000491	Lube Applicator	178	8107717	Slide Button (Ea.)
120	8000768	Combination Tool	179	8107587	5" Piston Replacement Kit
121	8107927	Surge Tank	180	8107419	Hitch Pin (Ea.)
122	8000572	3/4" x 90° Street Elbow	181	8107732	Handle Pad
123	8104573	3/4" Straight Fitting (Ea.)	182	8107983	Plastic Fastener Gauge Mounting
124	8101346	Hose Clamp (Ea.)	183	8107413	Serrated Washer H.D. Bolt 3/8" x 1", Gr.5
126			184	8109849	Inflation Warning Decal
127	8106284	1/4" Hose 13-1/4"	185	8101018	Washer
128	8183434	1/4" Tee with 1/8" Port	186	8107738	Spacer Bushing
129	8108968	300 Lb. Gauge	187	8107715	HHCS 3/8" - 16 x 1-1/4" GR.5 (Ea.)
130	8102390	1/4" Hose Fitting	188	8108109	Lower Shoe Adjustment Decal
131	8107768	Rubber Bumper Combo Tool Tube	189	8108147	Hold Down Tube
132	8106871	Inflation Hose Assembly	191	8111185	Nylon Tube 3/8" OD x 24"
133	8104968	Safety Valve 200 PSI	192	8110325	1/4" NPT Male Run Tee
134	8106270	Inflation Manifold	193	8101428	1/4" Hose Clamp
135	8103737	Release Valve	194	8109466	Valve
136	8108589	3/4" Hose 31"	195	8111255	Spl. Tee, 1/4 NPTx1/4x3/8
137	8101428	Hose Clamp	197	8110496	Volume Chamber
138	8410419	Air Chuck	198	8109471	1/8" Close Nipple
139	8107664	Bolt, Nut & Spacer Kit (Ea.)	199	8109472	1/8" In-Line Filter
141	8010027	1/2" Washer	200	8111083	Regulator
142	8107985	Air Gauge Kit Flange Mounting	201	8182035	St. Fitting 1/4" Tube x 1/8 NPT
143	8107517	Gauge Lens Screw On	202	8101428	1/4" Hose Clamp
144	8106289	1/4" Hose 22"	203	8103649	1/4" Hose 12"
145	8106301	1/4" Hex Whiz Lock Self-Tapping Screw, Gr.5	204	8182037	1/4" OD Nylon Tube 10"
146	8107924	3/4" Plastic Elbow	205	8101428	1/4" Hose Clamp
147	8105671	End Cap (1/4" Valve)	206	8110497	Fitting 90° Male Elbow
148	8104596	10-32 Self-Tapping Screw	207	8109468	Pressure Repeater
149	8104649	Poppet (1/4" Valve)	208	8109769	Decal Tire Bead Valve
150	8104600	1/4" Valve Complete	209	8111144	Operating Instructions
151	8104673	Bushing 1/4" Valve	210	8120408	HHCS 1/4" - 20 x 1-3/4", Gr.5
152	8104613	5/8" External Lock Washer	211	8143169	1/4" - 20 Whiz Lock Nut, Gr.5
153	8104611	5/8" Jam Nut N.F.	212	8181999	St. Fitting 3/8" Tube x 1/4 NPT
154	8106350	End Cap 3/4" Valve	213	8108842	Detent Label
155	8104651	Spring 3/4" Valve	214	8107637	Spring
156	8104652	Poppet 3/4" Valve	215	8107636	Positioning Cone
157	8106298	3/4" Valve Ported 1/4 - 18 NPT	216	8107790	Protector Set Boot, Set of 10
158	8104674	Bushing 3/4" Valve	217	8108397	Mounting Boot, 500 Bulk Pack
159	8104612	3/4" Lock Washer	218	8107641	Adapter Plate
160	8104610	3/4" Jam Nut N.F.	219	8107634	Cushion Thin
161	8106308	Air Flate Pedal	220	8107734	Spacer Cushion
162	8106281	1/4" Hose 20"	221	8107642	Shoe W/C
163	8109672	Air Tube Complete	222	8108398	Demount Boot, 500 Bulk Pack
164	8105552	1/4" Hose 28-3/4"	223	8107662	HHCS 1/2" x 5"
165	8107207	Lower Pivot Axle	224	8108303	Upper Bead Loosener Assembly
166	8107234	1/4 - 3/4 Brass Tee	225	8107651	Channel W/C
167	8107199	5" Cylinder Assembly Power Boost	226	8107647	Bar W/C
168	8000465	Cap O-Ring	227	8101039	1/2" Locknut
169	8106652	5" Cylinder Bottom Cap Weldment			
170	8107511	Spacer			
171	8107576	Piston Cup			
172	8107510	3/4" Jam Nut, Gr.5			
173	8107205	Piston Rod			
174	8107200	Cylinder Barrel Complete			
175	8106657	Wiper Seal			
176	8102840	Spring			
177	8107724	Clevis Pin			



Read and follow installation and maintenance instructions on this page and in the unit's Operation Instructions manual to help insure proper, safe operation and to obtain the best possible service life from the unit. Correct installation, regular inspections, and proper maintenance are essential to help prevent accidents and injuries.

Installation Instructions

1. The COATS 4050A should be securely bolted to the floor using the slotted holes on each side of the frame. Use all 4 anchor points. Use high-strength corrosion resistant industrial fasteners.

2. The operating pressure range at the machine must be 100 to 175 PSI. DO NOT EXCEED 175 PSI at the machine. Sufficient air pressure is required for good performance. The 4050A is supplied with a 1/4" male pipe thread for easy connection. The connection is located at the lower left corner on the operators side. DO NOT HAVE AN UNATTACHED, UNRESTRICTED AIR LINE AVAILABLE AT OR NEAR THE MACHINE. ALL AIR/SERVICE LINES AVAILABLE TO OPERATORS SHOULD BE THROUGH THE TIRE CHANGER.

3. Read and follow additional instructions in the machines Operating Instructions manual.

General Maintenance

1. The moving parts of the COATS 4050A are self-lubricating through the use of powdered metal and nylon bearings for extended trouble-free performance.

2. Lower bead loosener shoe adjustment:

A. Mount a 14" or 15" steel wheel without a tire on the machine table top.

B. Cycle the machine and note the clearance between the flange of the wheel and the small lower shoe (ref. 25). The proper shoe clearance is from 1/16" to 1/8". If clearance is not within these limits, the shoe must be adjusted.

C. To adjust the shoe, loosen 3/8"x1-1/2" bolt (ref. 32) and add or remove shims (ref. 31) to bring shoe to the correct adjustment.

D. Tighten the bolt (ref. 32) and check adjustment again as described in steps A and B above.

3. Air gauge calibration:

A. Mount a large 15" tire/wheel assembly on the machine table top. Pressurize the tire to 32 PSI. Measure the pressure with a high quality stick-type tire gauge. Connect the machine's air chuck to the tire valve.

B. If the gauge does not read 32 PSI, remove the screw-on gauge lens and loosen the two screws located at the edge of the dial face. Do not loosen the screws more than 3 turns.

C. Rotate the dial face until the 32 PSI graduation mark is aligned with the gauge pointer.

D. Tighten the dial face screws and clean and replace the screw-on lens.

E. If the gauge is inoperative or defective, replace it immediately. Order part number 107985 from the COATS Company, phone (615) 641-7533. If your machine is equipped with the optional pressure limiter, the function of the limiter should be checked weekly.

7" Cylinder Maintenance (Ref. 45)

Proper cylinder maintenance is necessary for safety and performance. The design of the hydraulically dampened 7" air cylinder (ref. 45) facilitates smooth, controlled bead loosening, mounting, and demounting. Internal sealing surfaces are chrome plated to provide long seal life. A small amount of oil is usually lost after a period of time in lubricating the seals. It is important that the cylinder be filled to the proper level at all times. If the oil becomes low, the machine will surge at the beginning of the stroke. Cylinder oil level should be checked before initial operation and semi-annually thereafter. If fast or jerky motion is noted, cease operation and check oil level immediately. A high quality hydraulic oil must be used (ref. 41). This can be ordered from COATS®, (615) 641-7533.

1. To add oil: Remove the front panel by removing four 3/8" bolts (ref. 100) and three 1/4" bolts (ref. 104).
2. Depress and hold foot pedal to extend the cylinder to the top of its stroke.
3. Carefully clean around the plastic breather plug (ref. 42), remove it, and place it where it will not pick up any dirt or debris. Fill the cylinder to within 1" to 1-3/16" from the access hole in the top. Be careful that no dirt falls in through the access hole.
4. Replace the plastic breather plug and replace the front panel.

5" Cylinder Maintenance (Ref. 167)

The cylinder requires periodic lubrication. This is performed without removing the cylinder from the machine.

1. Remove the front panel by removing four 3/8" bolts (ref. 100) and three 1/4" bolts (ref. 104).
2. Remove the plastic breather plug (ref. 42) on the cylinder. Add 1/2 ounce of 10W-30 motor oil with a spout-type oil can. **DO NOT FILL THE 5" CYLINDER WITH OIL.**
3. Check by actuating the machine several times to insure proper function. Add more oil if necessary.
4. Replace breather plug and front panel.



Read and follow all safety information on the machine. Always work carefully and safely.